



Rhode Island Convention Center Authority Invitation for Bids for an Electric Scissor Lift

The Rhode Island Convention Center Authority (the “Authority”) requests bids from qualified firms to provide a new 37’ foot 8” inch work height Electric Scissor lift, Skyjack model SJ4732 E or comparable for purchase for use at the Rhode Island Convention Center, One Sabin Street, Providence, Rhode Island. Specifications for the Scissor Lift can be found on Pages 5 and 6 of this document.

To the extent the Bidder intends to offer a comparable scissor lift, Bidder must submit with its bid the specifications of the scissor lift it is offering.

The Scissor Lift will be new and the latest state-of-the-art production model. The design and manufacture of the scissor lift shall be suitable for the intended use of the machine. Materials and finish shall be of the type to resist wear and corrosion from normal use and natural elements. The machine shall meet or exceed the following specifications:

- The scissor lift’s manufacturer shall provide parts and service manuals with the machine. The machine unit shall include parts, maintenance, and shop service manuals.
- The scissor lift shall be delivered completely and ready for operation.
- A vendor service representative shall install the Scissor Lift on-site and provide user training.

Added Options:

Option 1: Bidder is encouraged to submit an estimate to provide extended warranty coverage, for a period of three (3) and five (5) years after the initial warranty has expired on product.

Option 2: Bidder is encouraged to submit estimates to provide **ELEVATE** branded telematics three (3) and five (5) year plans.

Option 3: Bidder to also provide a scissor lift lease to purchase option.

Submission of Bids

Submit three (3) properly executed bids with any other documents required to be submitted in a sealed opaque envelope. The envelope shall be identified with the Bidder’s name and address, marked “Scissor Lift Bid” and delivered to the following address:

Attention: Howard Allen, Complex Purchasing Manager
Amica Mutual Pavilion
One LaSalle Square
Providence, RI 02903

Sealed Bids shall be submitted no later than **Monday, February 24, 2025 2:00PM, E.S.T.** on the response due date. Immediately thereafter, Bids will be opened and announced at the Amica Mutual Pavilion 3rd floor Boardroom, located at 1 LaSalle Square, Providence, RI 02903. Bids received after that time and date will be returned unopened. The Bidder shall assume full responsibility for timely delivery at the location designated for the receipt of Responses. Oral, telephonic or telegraphic bids are invalid and will not receive consideration.

SCHEDULE

Release Invitation to Bid	02/13/2025
Bid DUE (Prior to 2:00 PM)	02/24/2025

Instructions to Bidders

1. The bid must be signed by an officer of your firm with the authority to commit to the firm.
2. It is the intent of the Authority to purchase items that are operable within the system outlined in this Invitation; therefore, the Bidder is required to deliver a complete, working product. Should it be discovered that the Bidder failed to identify equipment required for fully operational systems, the Bidder shall supply those items at no charge to the Authority. This includes ALL of the hardware.
3. All prices shall be **FOB Rhode Island Convention Center**, 1 Sabin Street; Providence, RI 02903.
4. The successful Bidder must maintain a local service department within a 50-mile radius of the Rhode Island Convention Center and stock sufficient replacement parts and equipment components to provide the specified warranty service. The Bidder must be able to provide prompt, on-site service not to exceed a 24-hour response time, Monday through Friday.
5. Delivery (including inside delivery to site) must be included in the bid.
6. The contract awarded as a result of this RFP will be a firm one-time contract.

Form and Style of Bids

Bids must include the following:

- Company History/Qualification
 - Provide a detailed history of Bidder and a statement of qualifications
- References
 - Provide three (3) references who Bidder sold scissor lifts to on the attached sheet stating name, title, company, address, and telephone number
 - All Responses shall be typewritten without erasures or deletions.

Each copy of the Bid shall include the legal name of the Bidder and a statement identifying the Bidder as a sole proprietor, partnership, corporation, or other legal entity as appropriate. Each copy shall be signed by the person or persons legally authorized to bind the Bidder to a contract. A response by a corporation shall further give the state of incorporation and whether the Bidder is qualified to do business in Rhode Island as a foreign corporation. A Bid submitted by an agent shall have a current power of attorney attached certifying the agent's authority to bind the Bidder.

Selection

The award shall be made to the responsive and responsible Bidder whose bid price is the lowest evaluated or responsive bid price.

RIGHTS RESERVED TO THE AUTHORITY

Whenever the Authority deems it to be in the Authority's best interest, the Authority reserves the right, in its sole discretion, to cancel this Invitation to Bid, to reject any and all bids, to waive minor irregularities or informalities in a bid; to re-advertise; and to proceed in a manner other than awarding a contract under this Invitation. The Authority will not waive the requirement that bids be received by the Authority prior to the deadline for submission.

The Authority reserves the right to cancel negotiations with any Bidder at any time prior to a contract being fully executed by the proposer and the Authority.

The Authority reserves the right to interview any or all Bidders.

In addition to any other cause for rejection of a submittal stated in this Invitation, a bid may also be rejected if there is evidence of collusion among bidders, if the Bidder submitting it is in default or arrears under any prior or existing contract with the Authority or any other State of Rhode Island department or agency, or there is an unresolved claim between the proposer and the Authority or any other State of Rhode Island department or agency.

Any direct contacts made or attempted to be made by any Bidder with any Authority Board member prior to the selection of qualified bidders will automatically disqualify a proposer from any further consideration.

Bidders are considered to be irrevocable for a period of not less than sixty (60) days following the opening date and may not be withdrawn except with the express written approval of the Authority's Executive Director.

Bidders are advised that the Authority is a quasi-public agency of the State of Rhode Island and its records, including statements submitted in response to an Invitation are public records unless otherwise exempted under state law.

BID SHEET

Name of Company
or Corporation: _____

Company Address: _____

State and Date of Incorporation: _____

Project Manager to be Assigned: _____

Phone Number: _____

E-mail Address: _____

PRINCIPALS AND/OR MEMBERS OF CORPORATION

_____	_____
_____	_____
_____	_____

Purchase price: \$ _____

Lease to Purchase option: \$ _____

Three 3 and five 5-year plans added warranty options pricing:

3yr: \$ _____

5yr: \$ _____

ELEVATE branded telematics 3- and 5-year plan options pricing

3yr: \$ _____

5yr: \$ _____

Signature: _____ Date: _____

SJ4732 E

ELECTRIC SCISSORS



STANDARD FEATURES

- Drivable at full height
- Variable speed, dual rear wheel electric drive
- Dual holding brakes
- SKYCODED™ Color coded and numbered wiring system
- On-board visual interface with diagnostic capabilities
- Shroud style, impact resistant composite control box with extended cable
- Low battery indicator light on control box
- Proportional controls for drive & lift functions
- 4' (1.2 m) Roll out extension deck
- 24V DC Power source
- 110V AC Outlet on platform with GFI
- Low voltage battery protection
- 25% Gradeability
- Solid rubber, non-marking tires
- Pothole protection system
- Tilt alarm with drive & lift cut-out (3.5° x 1.5°)
- All motion audible alarm
- 28 mph (12.5 m/s) Wind rating
- Lanyard attachment points
- Operator horn
- Forklift pockets and tie down / lift lugs
- Overload sensing system
- Fold down hinged railing system
- Half height spring hinged entry gate
- Telematics ready
- 2-Year Gold Leaf Warranty (5-year structural warranty)



- 16% operational carbon saving compared to previous model



- Up to 20% improvement in duty cycle



- ZERO emissions



- <70 dB inherently quiet machine operation (excl. alarms)
- White noise/broadband alarms - *optional*



- 90% recyclable (by weight)



- 60% less hydraulic connections – reduces leak potential
- ECOTRAY leak containment - *optional*
- Bio-degradeable hydraulic oil - *optional*



- Telematics – remote diagnostics reduces site visits (operational carbon foot print)

SJ4732 E ELECTRIC SCISSORS

Dimensions		SJ4732 E
A Work Height		37' 8" (11.48 m)
B Raised Platform Height		31' 8" (9.65 m)
C Lowered Platform Height		50" (1.27 m)
D Overall Width		47" (1.20 m)
E Overall Length		91.6" (2.32 m)
F Stowed Height (Rails Up)		94" (2.39 m)
G Stowed Height (Rails Down)		78.5" (1.99 m)
H Platform Width (Inside Dimension)		42" (1.07 m)
I Platform Length (Inside Dimension)		83" (2.11 m)
Specifications		SJ4732 E
Extension Deck (Roll Out)		4' (1.22 m)
Ground Clearance (Pothole Raised)		4.0" (10.2 cm)
Ground Clearance (Pothole Deployed)		0.5" (1.3 cm)
Wheelbase		69" (1.75 m)
Weight		5,478 lbs (2,485 kg)
Gradeability		25%
Turning Radius (Inside)		28" (0.71 m)
Turning Radius (Outside)		104" (2.64 m)
Lift Time (With Rated Load)		64 sec
Lower time (With Rated Load)		41 sec
Drive Speed (Stowed)		2.1 mph (3.4 km/h)
Drive Speed (Raised)		0.6 mph (1.0 km/h)
Maximum Drive Height		Full Height
Capacity (Overall)		700 lbs (318 kg)
Distributed Capacity (Main Platform)		450 lbs (204 kg)
Distributed Capacity (Extension Deck)		250 lbs (113 kg)
Local Floor Load (With Rated Load)		124 psi (856 kPa)
Overall Floor Load (With Rated Load)		205 psf (1,001 kg/m ²)
Maximum # of persons at 0 mph (0 m/s) wind rating		2
Maximum # of persons up to 28 mph (12.5 m/s) wind rating		1
Tire Type		Solid, N/M
Tire Size		16 x 5 x 12

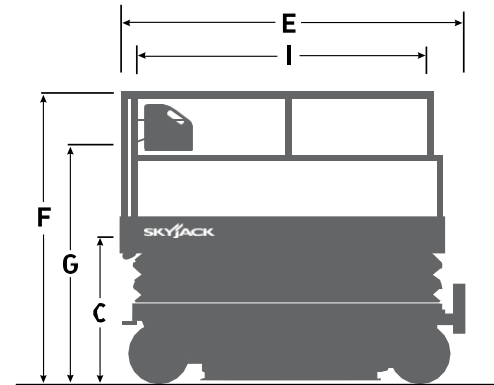
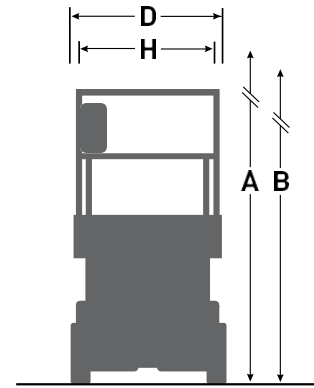

ACCESSORYZERS †

To Include in Quote:

- ECOTRAY leak containment system
- Secondary Guarding Lift Enable (SGLE)

OPTIONS †

To include in Quote:

- Dual flashing lights
- AGM Batteries
- Lockable swingout trays
- Full height spring hinged entry gate
- ELEVATE telematics (1-year, 3-year or 5-year plans available)
- Extended warranty (3-year or 5-year plans available)



Skyjack Head Office
 55 Campbell Rd. Guelph, ON Canada N1H 1B9
 Sales Inquiries: 1-877-755-4387 (1-877-SJLIFTS)
 Main Switchboard: 1-800-265-2738
 Phone: 519-837-0888
 Fax: 519-837-8104
 Email: skyjack@skyjack.com

www.skyjack.com

† Standard lead times may be increased when optional equipment is added, consult factory.
 ‡ Capacities and machine weights may differ when accessories and options are added.